



Developer Note

---

# Macintosh Color Classic



**Developer Note**

Developer Technical Publications  
© Apple Computer, Inc. 2000

🍏 Apple Computer, Inc.  
© 2000, Apple Computer, Inc.  
All rights reserved.

No part of this publication may be reproduced, stored in a retrieval system, or transmitted, in any form or by any means, mechanical, electronic, photocopying, recording, or otherwise, without prior written permission of Apple Computer, Inc. Printed in the United States of America.

The Apple logo is a registered trademark of Apple Computer, Inc. Use of the "keyboard" Apple logo (Option-Shift-K) for commercial purposes without the prior written consent of Apple may constitute trademark infringement and unfair competition in violation of federal and state laws.

No licenses, express or implied, are granted with respect to any of the technology described in this book. Apple retains all intellectual property rights associated with the technology described in this book. This book is intended to assist application developers to develop applications only for Apple Macintosh computers.

Apple Computer, Inc.  
20525 Mariani Avenue  
Cupertino, CA 95014  
408-996-1010

Apple, the Apple logo, APDA, AppleLink, AppleTalk, LaserWriter, Macintosh, and SANE are trademarks of Apple Computer, Inc., registered in the United States and other countries.

Apple Desktop Bus, Apple SuperDrive, and QuickDraw are trademarks of Apple Computer, Inc.

Adobe Illustrator and PostScript are trademarks of Adobe Systems Incorporated, which may be registered in certain jurisdictions.

Classic is a registered trademark licensed to Apple Computer, Inc. America Online is a service mark of Quantum Computer Services, Inc.

CompuServe is a registered service mark of CompuServe, Inc.

FrameMaker is a registered trademark of Frame Technology Corporation.

Helvetica and Palatino are registered trademarks of Linotype Company.

Internet is a trademark of Digital Equipment Corporation.

ITC Zapf Dingbats is a registered trademark of International Typeface Corporation.

NuBus is a trademark of Texas Instruments.

Trinitron is a trademark of Sony Corporation.

Varietyper is a registered trademark of Varietyper, Inc.

Simultaneously published in the United States and Canada.

#### LIMITED WARRANTY ON MEDIA AND REPLACEMENT

If you discover physical defects in the manual or in the media on which a software product is distributed, APDA will replace the media or manual at no charge to you provided you return the item to be replaced with proof of purchase to APDA.

**ALL IMPLIED WARRANTIES ON THIS MANUAL, INCLUDING IMPLIED WARRANTIES OF MERCHANTABILITY AND FITNESS FOR A PARTICULAR PURPOSE, ARE LIMITED IN DURATION TO NINETY (90) DAYS FROM THE DATE OF THE ORIGINAL RETAIL PURCHASE OF THIS PRODUCT.**

Even though Apple has reviewed this manual, **APPLE MAKES NO WARRANTY OR REPRESENTATION, EITHER EXPRESS OR IMPLIED, WITH RESPECT TO THIS MANUAL, ITS QUALITY, ACCURACY, MERCHANTABILITY, OR FITNESS FOR A PARTICULAR PURPOSE. AS A RESULT, THIS MANUAL IS SOLD "AS IS," AND YOU, THE PURCHASER, ARE ASSUMING THE ENTIRE RISK AS TO ITS QUALITY AND ACCURACY.**

**IN NO EVENT WILL APPLE BE LIABLE FOR DIRECT, INDIRECT, SPECIAL, INCIDENTAL, OR CONSEQUENTIAL DAMAGES RESULTING FROM ANY DEFECT OR INACCURACY IN THIS MANUAL, even if advised of the possibility of such damages.**

**THE WARRANTY AND REMEDIES SET FORTH ABOVE ARE EXCLUSIVE AND IN LIEU OF ALL OTHERS, ORAL OR WRITTEN, EXPRESS OR IMPLIED. No Apple dealer, agent, or employee is authorized to make any modification, extension, or addition to this warranty.**

**Some states do not allow the exclusion or limitation of implied warranties or liability for incidental or consequential damages, so the above limitation or exclusion may not apply to you. This warranty gives you specific legal rights, and you may also have other rights which vary from state to state.**

# Contents

|           |                                  |      |
|-----------|----------------------------------|------|
|           | Figures and Tables               | v    |
| Preface   | About This Note                  | vii  |
|           | Contents of This Note            | vii  |
|           | Supplemental Reference Documents | vii  |
|           | Conventions and Abbreviations    | viii |
|           | Typographical Conventions        | viii |
|           | Standard Abbreviations           | viii |
| Chapter 1 | Introduction                     | 1    |
|           | Summary of Features              | 2    |
|           | Compact Design                   | 2    |
|           | Front View                       | 3    |
|           | Back View                        | 3    |
|           | Access to the Logic Board        | 3    |
|           | Built-in Color Display           | 4    |
|           | Screen Control Pushbuttons       | 5    |
|           | Video RAM                        | 5    |
|           | RAM Expansion                    | 5    |
|           | RAM SIMM                         | 5    |
|           | RAM Configurations               | 6    |
|           | PDS Expansion Slot               | 6    |
|           | Floppy Disk Drive                | 7    |
|           | SCSI Connectors                  | 8    |
|           | Serial I/O Ports                 | 9    |
|           | ADB Ports                        | 9    |
|           | Power On and Off                 | 10   |
|           | Power Saver                      | 10   |
|           | Sound                            | 11   |
|           | Built-in Microphone              | 11   |
|           | Sound Input Jack                 | 12   |
|           | Sound Level Pushbuttons          | 12   |
|           | Keyboard                         | 12   |
|           | Ergonomic Mouse                  | 13   |

|           |                                      |    |
|-----------|--------------------------------------|----|
| Chapter 2 | <b>Architecture</b>                  | 15 |
|           | Block Diagram                        | 16 |
|           | Microprocessor                       | 16 |
|           | Spice Custom IC                      | 16 |
|           | Combo IC                             | 16 |
|           | ADB Controller                       | 18 |
|           | Sound Circuits                       | 18 |
|           | Sound Modes                          | 18 |
|           | Sample Rates                         | 19 |
|           | Address Maps                         | 19 |
|           | 24-Bit and 32-Bit Address Map        | 19 |
|           | I/O Address Map                      | 19 |
|           | RAM Addresses                        | 22 |
|           | Sound Buffer                         | 22 |
|           | Video RAM                            | 22 |
|           | Video Display Timing                 | 23 |
| Chapter 3 | <b>Expansion Card</b>                | 27 |
|           | The PDS Expansion Card               | 28 |
|           | Address Space for the Expansion Card | 28 |
|           | Power for the Expansion Card         | 30 |
|           | The PDS Expansion Slot               | 30 |
| Chapter 4 | <b>Software</b>                      | 35 |
|           | ROM Software                         | 36 |
|           | Unchanged Functions                  | 36 |
|           | MMU Initialization                   | 36 |
|           | Machine Identification               | 36 |
|           | RAM Sizing and Addressing            | 36 |
|           | One-Second Interrupt                 | 37 |
|           | Pushbutton Interrupts                | 37 |
|           | Screen Driver                        | 37 |
|           | Screen Driver Calls                  | 38 |
|           | Power Saver Software                 | 40 |
|           | Video Software                       | 40 |
|           | System Software                      | 40 |
|           | System Enabler                       | 40 |
|           | New Control Panels                   | 41 |
|           | Sound Control Panel                  | 41 |
|           | Screen Control Panel                 | 42 |
|           | <b>Index</b>                         | 43 |

# Figures and Tables

|                   |  |    |
|-------------------|--|----|
| Chapter 1         | Introduction   | 1  |
| <hr/>             |  |    |
| <b>Figure 1-1</b> | Front view of the Macintosh Color Classic computer                     | 3  |
| <b>Figure 1-2</b> | Back view of the Macintosh Color Classic computer                      | 4  |
| <b>Figure 1-3</b> | RAM configurations   | 6  |
| <b>Figure 1-4</b> | Screen control panel   | 11 |
| <b>Table 1-1</b>  | VRAM size and number of colors   | 5  |
| <b>Table 1-2</b>  | Pin assignments for the internal floppy disk connector                 | 7  |
| <b>Table 1-3</b>  | Pin assignments for the internal and external SCSI connectors          | 8  |
| <b>Table 1-4</b>  | Serial port pin assignments  | 9  |
| <b>Table 1-5</b>  | ADB connector pin assignments  | 10 |
| <b>Table 1-6</b>  | Reset and NMI key combinations   | 13 |
| Chapter 2         | Architecture   | 15 |
| <hr/>             |  |    |
| <b>Figure 2-1</b> | Block diagram  | 17 |
| <b>Figure 2-2</b> | 24-bit and 32-bit address map  | 20 |
| <b>Figure 2-3</b> | I/O address map  | 21 |
| <b>Figure 2-4</b> | Standard video timing  | 24 |
| <b>Figure 2-5</b> | Horizontal video timing for the Apple IIe card                         | 25 |
| <b>Table 2-1</b>  | Video parameters for the standard display                              | 23 |
| <b>Table 2-2</b>  | Video parameters for the Apple IIe display                             | 23 |
| Chapter 3         | Expansion Card   | 27 |
| <hr/>             |  |    |
| <b>Figure 3-1</b> | Generating the card select signal                                      | 28 |
| <b>Figure 3-2</b> | Design guide for the PDS card for the Macintosh Color Classic computer | 29 |
| <b>Table 3-1</b>  | Power available for the expansion card                                 | 30 |
| <b>Table 3-2</b>  | Signals on the expansion connector                                     | 31 |
| <b>Table 3-3</b>  | Processor-direct expansion connector signal descriptions               | 32 |
| <b>Table 3-4</b>  | Expansion slot signals not connected to the MC68030                    | 33 |

|                   |                      |    |
|-------------------|----------------------|----|
| <b>Figure 4-1</b> | Sound control panel  | 41 |
| <b>Figure 4-2</b> | Sound options        | 42 |
| <b>Figure 4-3</b> | Screen control panel | 42 |

# About This Note

---

This developer note provides information about the Macintosh Color Classic computer, a Macintosh model with an integrated color display.

**Note**

While every attempt has been made to verify the accuracy of the information presented here, it is subject to change without notice. The primary reason for releasing this type of product information is to provide the development community with essential product specifications, theory, and application information for the purpose of stimulating work on compatible third-party products. ♦

## Contents of This Note

---

The information in this developer note is divided into four chapters.

Chapter 1, “Introduction,” gives a summary of the features of the Macintosh Color Classic computer and describes its external features.

Chapter 2, “Architecture,” includes a block diagram and address maps and describes the integrated circuits that are specific to the Macintosh Color Classic.

Chapter 3, “Expansion Card,” describes the expansion card that plugs into the single expansion slot in the Macintosh Color Classic.

Chapter 4, “Software,” summarizes the features of the ROM software and tells how the system software operates on the Macintosh Color Classic.

## Supplemental Reference Documents

---

To supplement the information in this developer note, developers should have copies of the appropriate Apple reference books, including *Inside Macintosh* Volumes IV, V, and VI; *Guide to the Macintosh Family Hardware*, second edition; and *Designing Cards and Drivers for the Macintosh Family*, third edition. These books are available in technical bookstores and through APDA.

Developers should also have copies of *Macintosh IIsi, LC, and Classic Developer Notes*, available through APDA (catalog number M0991LL/A), and *Macintosh LC II Developer Note*, available on the developer CDs since April, 1992.

APDA is Apple’s worldwide source for over three hundred development tools, technical resources, training products, and information for anyone

interested in developing applications on Apple platforms. Customers receive the quarterly *APDA Tools Catalog* featuring all current versions of Apple development tools and the most popular third-party development tools. Ordering is easy; there are no membership fees, and application forms are not required for most of our products. APDA offers convenient payment and shipping options, including site licensing.

To order products or to request a complimentary copy of the *APDA Tools Catalog*, contact

APDA  
Apple Computer, Inc.  
P.O. Box 319  
Buffalo, NY 14207-0319

|                |   |
|----------------|---|
| Telephone      | 800-282-2732 (United States)<br>800-637-0029 (Canada)<br>716-871-6555 (International) |
| Fax            | 716-871-6511  |
| AppleLink      | APDA  |
| America Online | APDA  |
| CompuServe     | 76666,2405  |
| Internet       | APDA@applelink.apple.com  |

## Conventions and Abbreviations

---

This developer note uses typographical conventions and abbreviations that are standard in Apple publications.

### Typographical Conventions

---

This note uses the following typographical conventions.

New terms appear in **boldface** where they are first defined.

Computer-language text—any text that is literally the same as it appears in computer input or output—appears in *Courier* font.

### Standard Abbreviations

---

When unusual abbreviations appear in this book, the corresponding terms are also spelled out. Standard units of measure and other widely used abbreviations are not spelled out.



## P R E F A C E

Here are the standard units of measure used in Apple reference books:

|    |              |     |              |
|----|--------------|-----|--------------|
| A  | amperes      | MB  | megabytes    |
| GB | gigabytes    | MHz | megahertz    |
| Hz | hertz        | ms  | milliseconds |
| K  | 1024         | ns  | nanoseconds  |
| KB | kilobytes    | V   | volts        |
| mA | milliamperes | W   | watts        |

Here are the abbreviations used in Apple reference books:

|        |  |
|--------|--|
| $\$n$  | hexadecimal value $n$  |
| AC     | alternating current  |
| ADB    | Apple Desktop Bus  |
| CD-ROM | compact-disk read-only memory  |
| CLUT   | color look-up table  |
| DAC    | digital-to-analog converter  |
| IC     | integrated circuit   |
| I/O    | input/output   |
| LS     | low-power Shottky (used as a standard for IC device loads)           |
| MMU    | memory-management unit   |
| NMI    | non-maskable interrupt   |
| NTSC   | National Television Standards Committee (a video standard)           |
| PAL    | phase-alternating lines (a video standard)                           |
| PDS    | processor-direct slot  |
| RAM    | random-access memory   |
| ROM    | read-only memory   |
| RGB    | red-green-blue (a video standard)                                    |
| SANE   | Standard Apple Numerics Environment                                  |
| SCSI   | Small Computer System Interface                                      |
| SVGA   | super VGA (a video card used with PC-type computers)                 |
| TTL    | transistor-transistor logic (used as a standard for IC device loads) |
| VGA    | video graphics adapter (a video card used with PC-type computers)    |
| VRAM   | video RAM  |



# Introduction

---

## Introduction

The Macintosh Color Classic<sup>®</sup> computer is a compact Macintosh computer with a built-in color display. It is approximately the same size as the Macintosh Classic but has many of the performance features of the Macintosh LC II.

This chapter outlines the main features of the Macintosh Color Classic and describes its appearance and external features.

## Summary of Features

---

Here is a summary of the hardware features of the Macintosh Color Classic computer. Individual features are described in the sections that follow.

- compact design with built-in 10-inch color display
- Motorola MC68030 microprocessor running at 16 MHz (15.6672 MHz)
- compact case slightly larger than the Macintosh Classic and Classic II
- built-in video hardware using separate video RAM
- installed RAM capacity of 4 MB, expandable to 10 MB
- 1 MB ROM in a SIMM socket; optional expansion to 2 MB
- internal hard disk, 40 MB, 80 MB, or 160 MB capacity, using the internal SCSI connector; external SCSI port for additional SCSI devices
- internal Apple SuperDrive high-density floppy disk drive with 1.44 MB capacity
- standard Macintosh I/O ports: two ADB ports, two serial ports, and SCSI port
- built-in microphone and internal speaker; sound input and output jacks
- processor-direct slot (PDS) for hardware expansion; compatible with the PDS on the Macintosh LC II
- power on and off from the keyboard
- pushbuttons on the front panel to control sound volume and display intensity
- power-saver mode allows software to turn off the display monitor when the machine is unused for a set period of time

## Compact Design

---

The Macintosh Color Classic computer has a compact design similar to that of the Macintosh Classic, but with a color display and other added features.

## Front View

Figure 1-1 shows the Macintosh Color Classic computer from the front. The figure shows the display screen, the floppy-disk insertion slot, and the pushbuttons.

**Figure 1-1** Front view of the Macintosh Color Classic computer

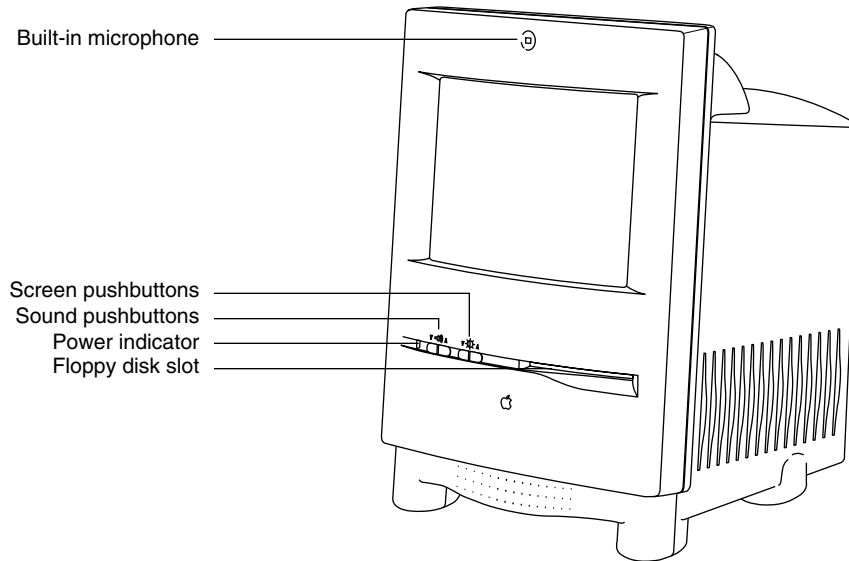

## Back View

Figure 1-1 shows the Macintosh Color Classic computer from the back. The master power switch is located just beneath the fan grille. The external connectors are located in a row across the lower part of the back.

## Access to the Logic Board

Just above the row of connectors on the back of the computer are two projecting tabs. By pulling on the tabs, the user can remove the connector panel and gain access to the main logic board. The logic board plugs into connectors at the front so that the user can remove it from the case by pulling it out the back. Once the board has been removed, the user can add expansion RAM or plug in an expansion card, as described in later sections of this note.

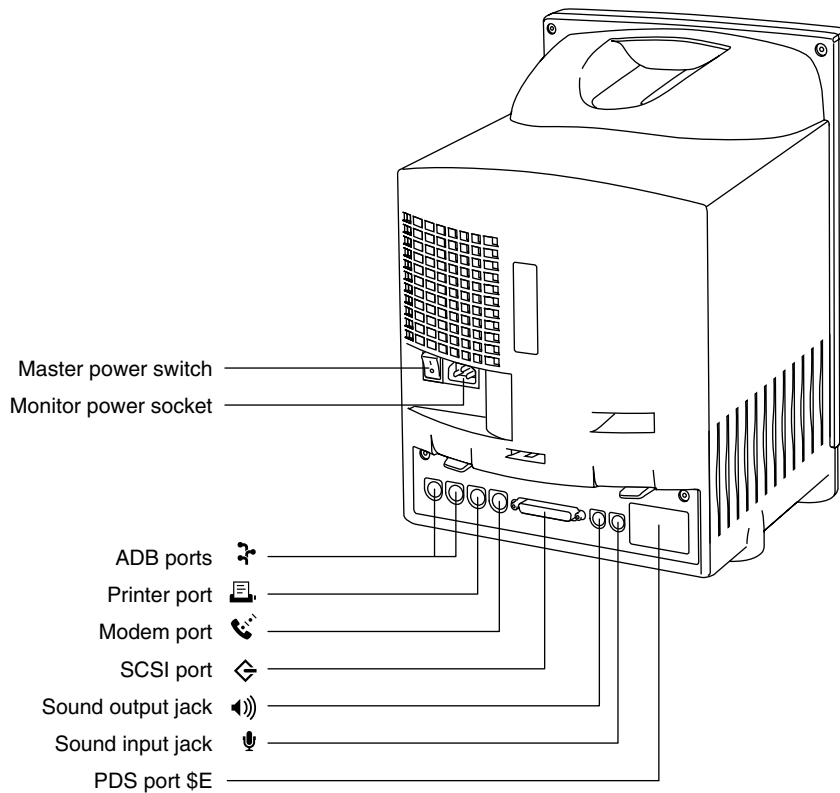
**Figure 1-2** Back view of the Macintosh Color Classic computer

## Built-in Color Display

The Macintosh Color Classic computer has a built-in color display with a 10-inch Trinitron monitor. Like the video interface in the Macintosh LC II model, the video interface in the Macintosh Color Classic uses separate VRAM for the screen buffer. The Macintosh Color Classic does not have an external video connector.

The display screen in the Macintosh Color Classic displays the same amount of information as the Macintosh LC II with the Macintosh 12" RGB monitor: 512 by 384 pixels.

### Note

The actual screen size of the Macintosh Color Classic computer is approximately the same as that of the Macintosh Classic, which has always been called a 9-inch display. The display in the Macintosh Color Classic is called a 10-inch display because the CRT has a 10-inch diagonal; that is the conventional way of specifying the size of a video display. ♦

## Introduction

The Macintosh Color Classic computer also provides an optional 16-color, 560-by-384-pixel display mode when an Apple IIe Card is installed in the expansion slot.

## Screen Control Pushbuttons

---

The Macintosh Color Classic has two pairs of pushbuttons on the front panel. One pair of pushbuttons controls the intensity of the screen: pressing one button causes the intensity to increase, and pressing the other causes the intensity to decrease. (The other pair of pushbuttons controls the sound level.)

## Video RAM

---

The Macintosh Color Classic comes with 256 KB of video RAM (VRAM) and a SIMM socket for expanding the VRAM to a total of 512 KB. The VRAM expansion SIMM is the same 68-pin SIMM used with the Macintosh Quadra computers.

The basic 256 KB video RAM provides up to 8 bits per pixel; the screen displays 256 colors, selectable from a range of 16 million. With 512 KB of VRAM, the Macintosh Color Classic computer can display up to 16 bits per pixel, which provides 32,768 colors. If the VRAM SIMM has been installed, the user can set the display to 16 bits per pixel by opening the Monitors control panel and choosing Thousands.

**Table 1-1** VRAM size and number of colors

| VRAM size | Bits per pixel    | Number of colors                                    |
|-----------|-------------------|---|
| 256 KB    | 1, 2, 4, or 8     | 2, 4, 16, or 256                                    |
| 512 KB    | 1, 2, 4, 8, or 16 | 2, 4, 16, 256, or 32,768<br>(only 15 bits are used) |

## RAM Expansion

---

The Macintosh Color Classic computer comes with 4 MB of RAM built in. By installing two SIMMs, the user can expand the RAM up to a maximum of 10 MB.

### RAM SIMM

---

The Macintosh Color Classic accepts two standard 30-pin RAM SIMMs. The SIMMs must be the same size, either 1 MB, 2 MB, or 4 MB. The access time of the RAM must be 100 ns or less.

## RAM Configurations

The Macintosh Color Classic accommodates 2 MB, 4 MB, or 8 MB of additional RAM. Figure 1-3 shows the configurations for different amounts of RAM.

The upper 2 MB of built-in RAM is always mapped into the upper 2 MB of the computer's 10-MB RAM address space. For more information, see the section "RAM Addresses" beginning on page 22.

**Note**

A Macintosh Color Classic computer with 4 MB of RAM soldered to the main logic board can be expanded to a total of 10 MB by installing two 4 MB SIMMs. The computer then actually contains 12 MB of RAM, but 2 MB of the original 4 MB is no longer addressable. The resulting 10-MB address map is shown in Figure 1-3. ♦

**Figure 1-3** RAM configurations

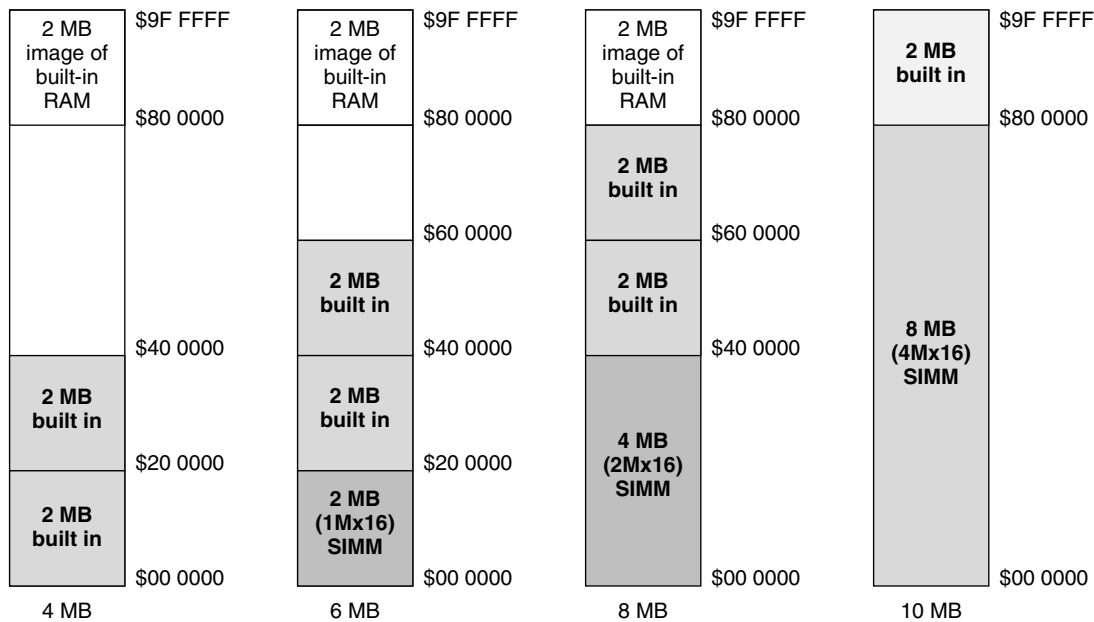

## PDS Expansion Slot

The Macintosh Color Classic computer has a single internal 96-pin connector that provides direct access to the 68030 processor from an optional expansion card. The expansion card is similar to the PDS (processor-direct-slot) card for the Macintosh LC II.



## Introduction

Chapter 3, “Expansion Card,” describes the signals on the PDS connector and gives the specifications of a PDS card for the Macintosh Color Classic.

**Note**

The PDS connector in the Macintosh Color Classic accepts the Apple IIe card for the Macintosh LC. The internal display provides a 560-by-384, 16-color display for running Apple IIe software. ♦

## Floppy Disk Drive

---

The Macintosh Color Classic computer supports one internal high-density floppy disk drive (Apple SuperDrive). The drive is connected to the logic board by a 20-pin connector. shows the pin assignments for the floppy disk connector.

**Table 1-2** Pin assignments for the internal floppy disk connector

| Pin number | Signal name | Signal description             |
|------------|-------------|--------------------------------|
| 1          | GND         | Ground                         |
| 2          | PH0         | Phase 0: state-control line    |
| 3          | GND         | Ground                         |
| 4          | PH1         | Phase 1: state-control line    |
| 5          | GND         | Ground                         |
| 6          | PH2         | Phase 2: state-control line    |
| 7          | GND         | Ground                         |
| 8          | PH3         | Phase 3: register write strobe |
| 9          | n.c.        | Not connected                  |
| 10         | /WRREQ      | Write data request             |
| 11         | +5V         | +5 volts                       |
| 12         | SEL         | Head select                    |
| 13         | +12V        | +12 volts                      |
| 14         | /ENBL       | Drive enable                   |
| 15         | +12V        | +12 volts                      |
| 16         | RD          | Read data                      |
| 17         | +12V        | +12 volts                      |
| 18         | WR          | Write data                     |
| 19         | +12V        | +12 volts                      |
| 20         | n.c.        | Not connected                  |

## SCSI Connectors

---

The SCSI connectors on the Macintosh Color Classic are the same as in other desktop Macintosh computers. The internal SCSI connector is a 50-pin connector with the standard SCSI pin assignments. The external SCSI connector is a 25-pin D-type connector with the same pin assignments as other Apple SCSI devices. Table 1-3 shows the pin assignments on the internal and external SCSI connectors.

**Table 1-3** Pin assignments for the internal and external SCSI connectors

| Internal (50-pin)          | External (25-pin)           | Signal name |
|----------------------------|-----------------------------|-------------|
| 48                         | 1                           | /REQ        |
| 42                         | 2                           | /MSG        |
| 46                         | 15                          | /C/D        |
| 50                         | 3                           | /I/O        |
| 40                         | 4                           | /RST        |
| 32                         | 17                          | /ATN        |
| 38                         | 5                           | /ACK        |
| 36                         | 6                           | /BSY        |
| 44                         | 19                          | /SEL        |
| 18                         | 20                          | /DBP        |
| 2                          | 8                           | /DB0        |
| 4                          | 21                          | /DB1        |
| 6                          | 22                          | /DB2        |
| 8                          | 10                          | /DB3        |
| 10                         | 23                          | /DB4        |
| 12                         | 11                          | /DB5        |
| 14                         | 12                          | /DB6        |
| 16                         | 13                          | /DB7        |
| 26                         | 25                          | TPWR        |
| All odd pins<br>(25 total) | 7, 9, 14, 16, 18,<br>and 24 | GND         |
| 20, 22, 24, 34             | –                           | n.c.        |

## Serial I/O Ports

---

The Macintosh Color Classic computer has two serial ports that use standard 8-pin mini-DIN connectors. Table 1-4 shows the pin assignments for the serial ports.

The serial ports are the same as those on the Macintosh LC and Macintosh LC II except for the addition of the GPi (general purpose input) signal on pin 7. The GPi signal for each port connects to the corresponding Data Carrier Detect input on the SCC. (The SCC or Serial Communications Controller is part of the Combo IC; see the section “Combo IC” on page 16.) On serial port A (the modem port), the GPi line can be connected to the Receive/Transmit Clock (RTxCA) on the SCC. That connection supports devices that provide separate transmit and receive data clocks, such as synchronous modems.

**Table 1-4** Serial port pin assignments

| Pin number | Signal description    |
|------------|-----------------------|
| 1          | Handshake output      |
| 2          | Handshake input       |
| 3          | Transmit data -       |
| 4          | Ground                |
| 5          | Receive data -        |
| 6          | Transmit data +       |
| 7          | General-purpose input |
| 8          | Receive data +        |

## ADB Ports

---

The ADB ports on the Macintosh Color Classic computer are functionally the same as on other Macintosh computers.

The ADB is a single-master, multiple-slave, serial communications bus that uses an asynchronous protocol and connects keyboards, graphics tablets, mouse devices, and other devices to the computer. The custom ADB microcontroller drives the bus and reads status from the selected external device. A 4-pin miniature-DIN connector connects the ADB controller to the outside world. Table 1-5 lists the ADB connector pin assignments.

**Table 1-5** ADB connector pin assignments

| Pin number | Name | Description  |
|------------|------|--|
| 1          | ADB  | Bidirectional data bus used for input and output. It is an open-collector signal pulled up to +5 volts through a 470 ohm resistor on the main logic board. |
| 2          | PSW  | Power-on signal that generates Reset and Interrupt key combinations.   |
| 3          | +5V  | +5 volts from the computer. A 1-ampere fuse at the output satisfies safety requirements.   |
| 4          | GND  | Ground from the computer.  |

**Note**

The total current for all devices connected to the +5V pin on the ADB is 500 mA. Each device should use no more than 100 mA. ♦

## Power On and Off

---

The master power switch on the back of the computer must be in the On position for the computer to operate. As long as the master power switch is in the On position, the user can turn the power off and on by pressing the power key on the keyboard.

**Note**

If you plan to leave the computer turned off for an extended period of time, you should flip the master power switch to the Off position. ♦

If the user attempts to turn off the computer—using either the power key or the Shutdown menu item—while files are still open, the system displays an alert box so that the user can avoid losing data. If the user turns off the master power switch while the computer is operating, the computer shuts off immediately, without performing the safe shutdown.

## Power Saver

---

The power saver is an optional feature that automatically turns off the display whenever the Macintosh Color Classic computer is turned on but is not used for more than a set period of time. The user selects the power saver and sets the length of time before the screen turns off by means of the Screen control panel, shown in Figure 1-4. After the power saver has turned the display off, the software turns the display back on again whenever the user moves the mouse or presses a key on the keyboard.

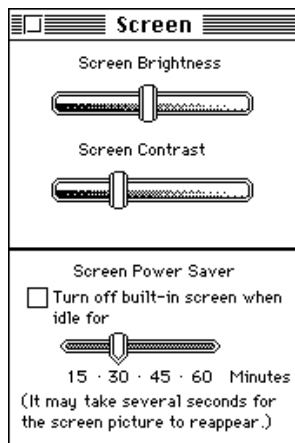
**Figure 1-4** Screen control panel**Note**

It may take a few seconds for the picture to reappear. To let the user know that it has responded to the user's action, the computer emits a series of beeps while this is happening. ♦

Applications can turn the display on and off by making calls to the screen driver. See the section "Power Saver Software" beginning on page 40.

## Sound

---

Like other Macintosh computers, the Macintosh Color Classic can create sounds digitally and play the sounds through its internal speaker or send the sound signals out through the sound out connector. For recording sound, the Macintosh Color Classic has a built-in microphone as well as an external sound input jack.

The sound system includes a playthrough feature that allows an external audio source to be mixed with computer-generated sound and played through the speaker or the sound out connector. See the section "Sound Modes" on page 18.

### Built-in Microphone

---

The Macintosh Color Classic computer has a built-in microphone at the front of the case. The microphone is connected internally to the main logic board.

The user selects the built-in microphone as the sound source by using the Sound control panel. See the section "Sound Control Panel" on page 41.

## Sound Input Jack

---

There is a sound input jack on the back of the computer for connecting an external microphone or other sound source. The sound input jack accepts a standard 1/8-inch phone plug, either monophonic or stereophonic (two signals plus ground).

The sound input jack accepts either the external microphone for the Macintosh Color Classic or a pair of line-level (amplified) signals. When the user selects the corresponding input device in the Sound control panel, the computer sets the gain appropriately. The internal circuitry mixes the pair of stereophonic signals into a monophonic signal.

**Note**

The Macintosh external microphone requires power from the main computer, which it obtains by way of an extra-long plug that makes contact with a 5-volt pin inside the sound input jack. ♦

## Sound Level Pushbuttons

---

The Macintosh Color Classic computer has two pairs of pushbuttons on the front panel. One pair of buttons controls the sound level: pressing one button causes the level to increase, and pressing the other causes the level to decrease. (The other pair of pushbuttons controls the intensity of the display.) Each time you press one of the sound control pushbuttons, the computer plays a sound to confirm the new level setting.

## Keyboard

---

The Macintosh Color Classic computer has a separate keyboard like the one used with the Macintosh LC II. The keyboard has a power key, identified by the symbol ⏻.

There are no programmer's switches on the Macintosh Color Classic case, so the Reset and NMI functions are generated by pressing the Power key on the keyboard while holding down other keys, as shown in Table 1-6. The Command key is identified by the symbols ⌘ and ⌘.

**Note**

The user must hold down the key combinations for at least 1 second to allow the ADB microcontroller enough time to respond to the NMI or hard-reset signal. ♦

**Table 1-6** Reset and NMI key combinations

---

| <b>Key combination</b>                 | <b>Function</b>     |
|--|---------------------|
| Power (⏻)                              | Power on and off    |
| Command-Power (⌘-⏻)                    | NMI (always active) |
| Control-Command-Power<br>(control-⌘-⏻) | Reset               |

**Note**

The NMI in the Macintosh Color Classic computer can always be activated from the keyboard. This is a change from the Macintosh LC computer, where the keyboard NMI function can be deactivated by the software. ♦

## Ergonomic Mouse

---

The Macintosh Color Classic computer has a new, smaller mouse. The operation of the mouse is the same as that of the Macintosh low-power mouse, but the case is smaller and more comfortable to use.





# Architecture

---

## Architecture

This chapter describes the architecture of the Macintosh Color Classic computer. It describes the main components on the logic board and explains the features that are different from those of earlier Macintosh computers.

## Block Diagram

---

The architecture of the Macintosh Color Classic computer is based on the design of the Macintosh LC II. The Macintosh Color Classic uses several new custom ICs, as shown in the block diagram in Figure 2-1.

### Microprocessor

---

The Macintosh Color Classic computer uses a Motorola MC68030 microprocessor running at a clock speed of 15.6772 MHz.

The Macintosh Color Classic does not ship with a built-in floating-point unit (FPU). The main circuit board has a socket for adding an FPU. Also, an expansion board can provide an FPU, because the /FPU select signal is available on the expansion connector. See Chapter 3, “Expansion Card.”

### Spice Custom IC

---

A custom IC called Spice combines several functions performed by individual ICs in older machines:

- timing and clock generation
- memory mapping
- VIA1 and VIA2 registers
- video addressing and timing
- SWIM2 floppy-disk interface
- sound timing and control
- interface to front-panel pushbuttons

The VIA functions are similar to the ones in the Macintosh LC II. The first VIA is a full-function VIA, and the second is a set of registers like those in the RBV custom IC.

### Combo IC

---

In the Macintosh Color Classic computer, the functions of two interface ICs, the SCC (85C30) and the SCSI (53C80), are combined into one device, the Combo IC (85C80). The SCSI port on the Macintosh Color Classic is the same as on the Macintosh LC II.

Figure 2-1 Block diagram

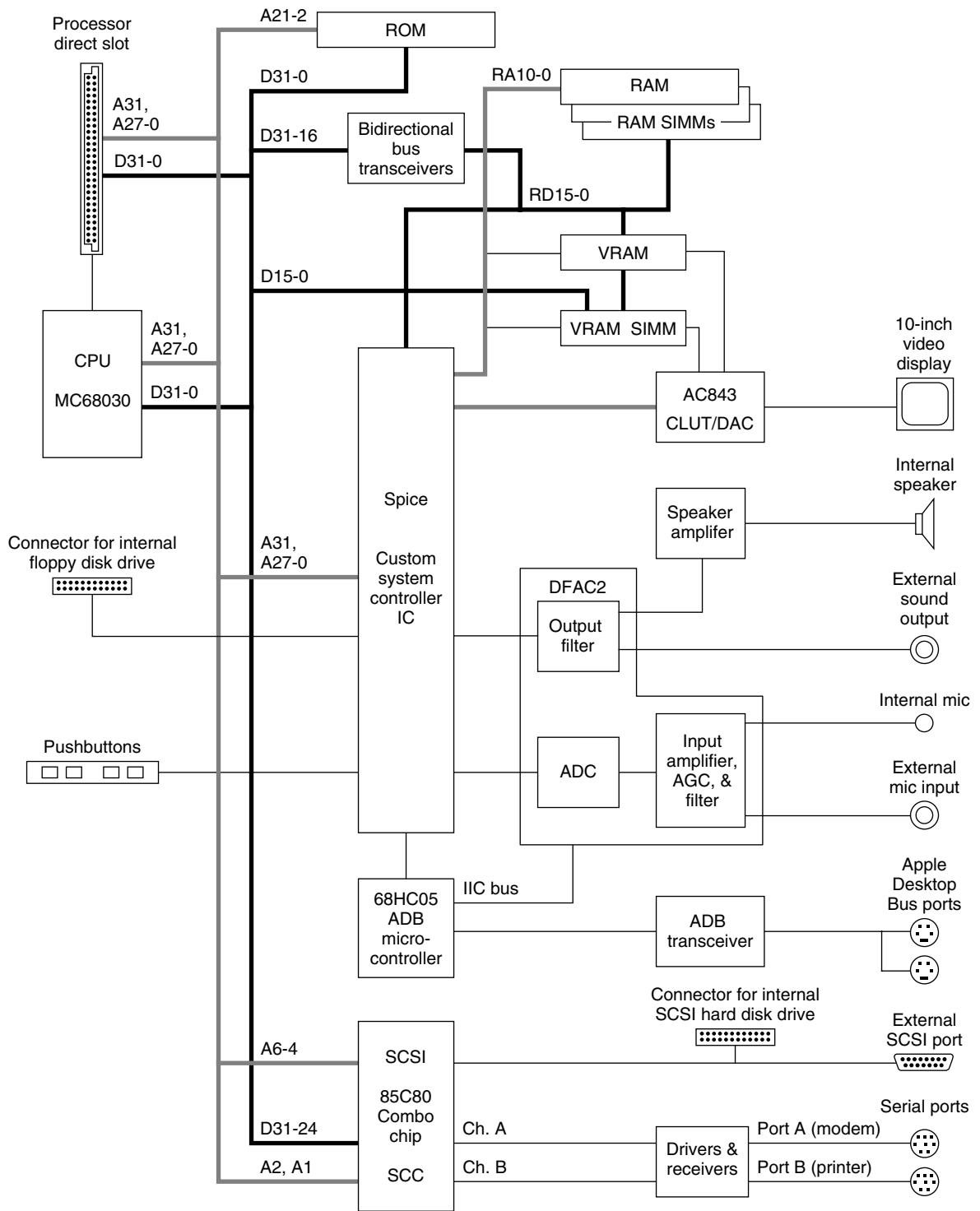

## Architecture

The SCC (serial) ports are also like their counterparts on the Macintosh LC II except that they include the GPi signal (on pin 7). The GPi (general-purpose input) signal can be used for input handshaking or for a receive-clock input to support a synchronous modem.

## ADB Controller

---

The ADB controller IC is a version of the 68HC05 microcontroller. It provides the ADB interface as well as parameter RAM, real-time clock, and soft-power control. For a description of soft power, see the section “Power On and Off” on page 10.

## Sound Circuits

---

The sound processing devices in the Macintosh Color Classic computer are built into a custom IC called the DFAC2. The Spice custom IC performs some sound routing and control functions.

For sound input, the DFAC2 processes the signal from the internal microphone or the sound input connector through a sound input amplifier with AGC, an input filter, an A/D converter, and the necessary switching circuits.

For sound output, circuits in the Spice custom IC receive data from the sound buffer and generate a pulse-width modulated (PWM) signal that is sent to the DFAC2. After low-pass filtering in the DFAC2, the signal is sent to the sound output connector and to a separate amplifier that drives the built-in speaker. Inserting a plug into the sound output connector disconnects the internal speaker.

## Sound Modes

---

The DFAC2 is normally used in one of four modes of operation:

- Sound playback: computer-generated sound is sent to the speaker and the Sound Out jack.
- Sound playback with playthrough: computer sound and sound input mixed and sent to the output.
- Sound record: the preferred method for recording, especially when using the built-in microphone.
- Sound record with playthrough: input sound recorded and also fed through to the output.

As in the Macintosh LC, an application can select the sound mode by means of a call to the Sound Manager.

Because some of the sound processing devices are used for both input and output, the Macintosh Color Classic computer cannot play and record sound at the same time.

## Architecture

**Note**

To prevent feedback that might be audible, an application should not select playthrough mode when either microphone has been selected as the sound input source. See the section “Sound Control Panel” on page 41. ♦

**Sample Rates**

---

The Macintosh Color Classic records and plays back sound at either of two sample rates: 11K samples per second and 22K samples per second. For sound input, the system switches the input filter between two cutoff frequencies that correspond to the two sampling rates: 3.5 kHz cutoff for the 11K sample rate and 7 kHz cutoff for the 22K sample rate.

Similarly on playback, the system switches between a filter with a 3.5 kHz cutoff frequency for sounds at 11K samples per second and a 7 kHz filter for 22K samples per second.

## Address Maps

---

This section shows simplified address maps of the Macintosh Color Classic computer.

**Note**

Developers should not use actual hardware addresses in applications, but always communicate with hardware devices by means of system software. ♦

**24-Bit and 32-Bit Address Map**

---

Macintosh Color Classic supports both 24-bit and 32-bit addressing. Figure 2-2 shows the relationship between the 24-bit addresses and the 32-bit addresses. The address map is similar to that of the Macintosh LC.

**I/O Address Map**

---

Figure 2-3 shows the I/O address assignments. The 24-bit addresses of the I/O devices are just the low-order 24 bits of the 32-bit addresses shown in the figure.

**Figure 2-2** 24-bit and 32-bit address map

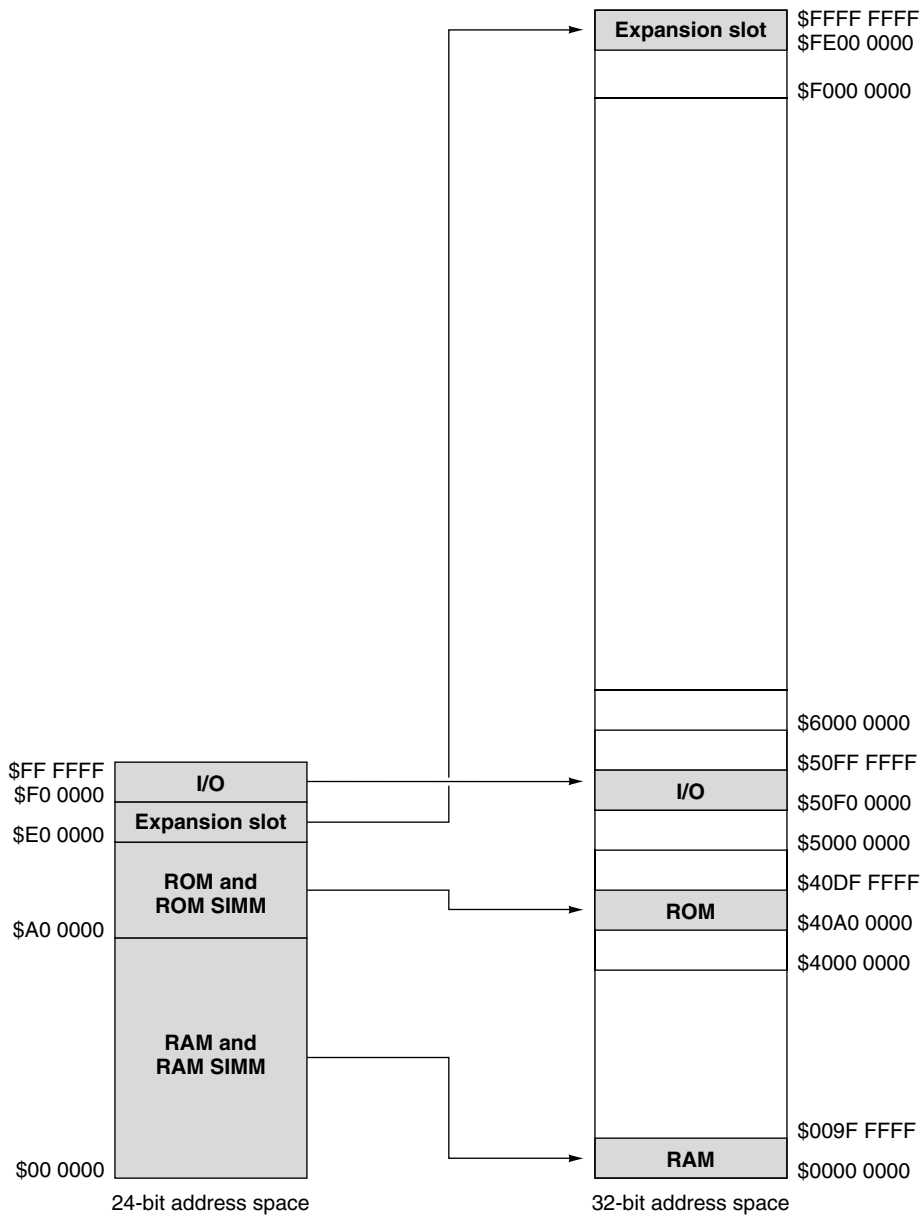

**Figure 2-3** I/O address map

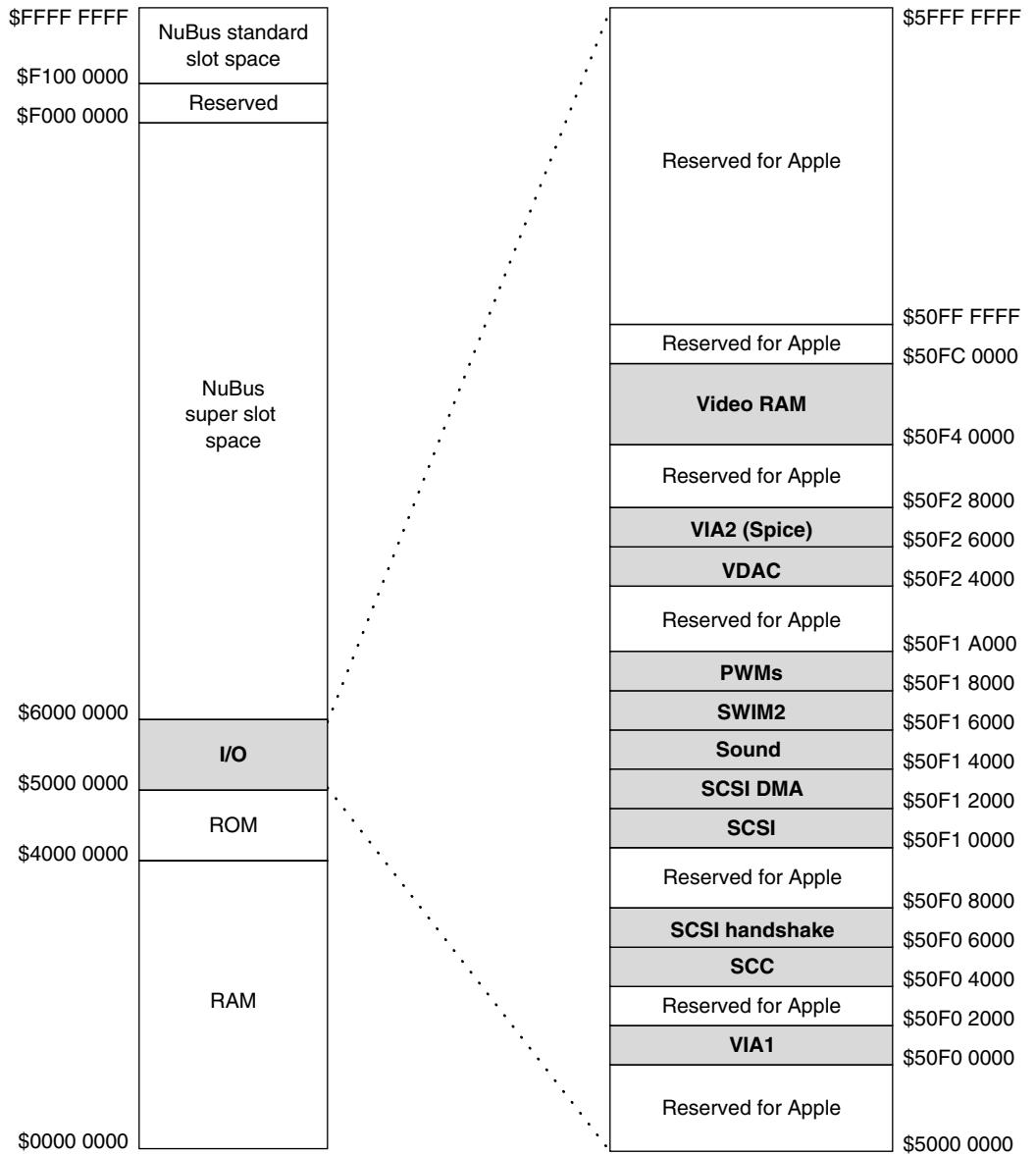

## RAM Addresses

---

The first 10 MB of the address space are reserved for RAM. The actual amount of RAM installed can be from 2 MB to 10 MB. At startup time, a routine in the ROM examines the RAM and stores the size in a low-memory global variable.

The Macintosh Color Classic always allows the upper 2 MB of built-in RAM to be addressed in the topmost 2 MB of the 10 MB address space, as shown in Figure 1-3 on page 6. The system software uses the topmost 2048 bytes of RAM to store system information.

## Sound Buffer

---

The sound buffer is stored in the built-in RAM and addressed starting at location \$009F F000. The sound buffer occupies 1022 bytes, but those bytes are stored as the high bytes of 16-bit words, so that the sound buffer actually uses up 2048 bytes of space. The sound buffer is always read and written to by way of the sound FIFO port, which is located at the same memory address as the Channel-A (left channel) FIFO in the Macintosh II computer. The Macintosh II and other models that use the Apple Sound Chip (ASC) also have a second address for the Channel-B (right channel) FIFO. In the Macintosh Color Classic, attempts to write to Channel B have no effect.

## Video RAM

---

The Macintosh Color Classic computer uses separate video RAM (VRAM) to store the screen buffer. The video RAM is addressed in the I/O space, as shown in Figure 2-3.

The computer comes with 256 KB of VRAM soldered to the main logic board. A 68-pin SIMM socket accepts an additional 256 KB for a total of 512 KB of VRAM. The 256 KB VRAM SIMM is the same size and has the same pin assignments as the VRAM expansion SIMM for the Macintosh Display Card 8•24. The system interface to the built-in VRAM is a 16-bit data bus using bits 31–16 and the interface to the VRAM SIMM uses bits 15–0. When the VRAM SIMM is installed, the data bus to the VRAM is 32 bits wide, which improves the computer's performance.

### Note

The 256 KB VRAM SIMM used in the Macintosh Color Classic computer and the Macintosh Display Card 8•24 is not the same as the 512 KB VRAM SIMM used in the Macintosh LC and Macintosh LC II. ♦

A color look-up table (CLUT) is used in all video modes. With the Monitors dialog box set for a monochrome display, the CLUT is still used, but all three color components (R, G, B) are the same.



## Video Display Timing

---

The standard video display on the Macintosh Color Classic computer has the same number of pixels as the display used with the Macintosh LC: 512 by 384 pixels. Table 2-1 lists the video parameters and Figure 2-4 shows the timing and the synchronizing signals.

When the Apple IIe Card for Macintosh is installed in the expansion slot, the Macintosh Color Classic uses a timing signal from the card to generate a video display with the necessary 560-pixel horizontal timing. Table 2-2 lists the video parameters for the Apple IIe display and Figure 2-5 shows the horizontal timing and synchronizing signals. (The vertical timing for the Apple IIe display is the same as for the standard display.)

**Table 2-1** Video parameters for the standard display

---

|            |                   |
|------------|-------------------|
| Dimensions | 512 by 384 pixels |
| Dot clock  | 15.6672 MHz       |
| Dot time   | 63.83 ns          |
| Line rate  | 24.48 kHz         |
| Line time  | 40.85 $\mu$ s     |
| Frame rate | 60.15 Hz          |
| Frame time | 16.63 ms          |

**Table 2-2** Video parameters for the Apple IIe display

---

|            |                   |
|------------|-------------------|
| Dimensions | 560 by 384 pixels |
| Dot clock  | 17.234 MHz        |
| Dot time   | 58.02 ns          |
| Line rate  | 24.48 kHz         |
| Line time  | 40.85 $\mu$ s     |
| Frame rate | 60.15 Hz          |
| Frame time | 16.63 ms          |

**Figure 2-4** Standard video timing

---

Architecture

Horizontal timing

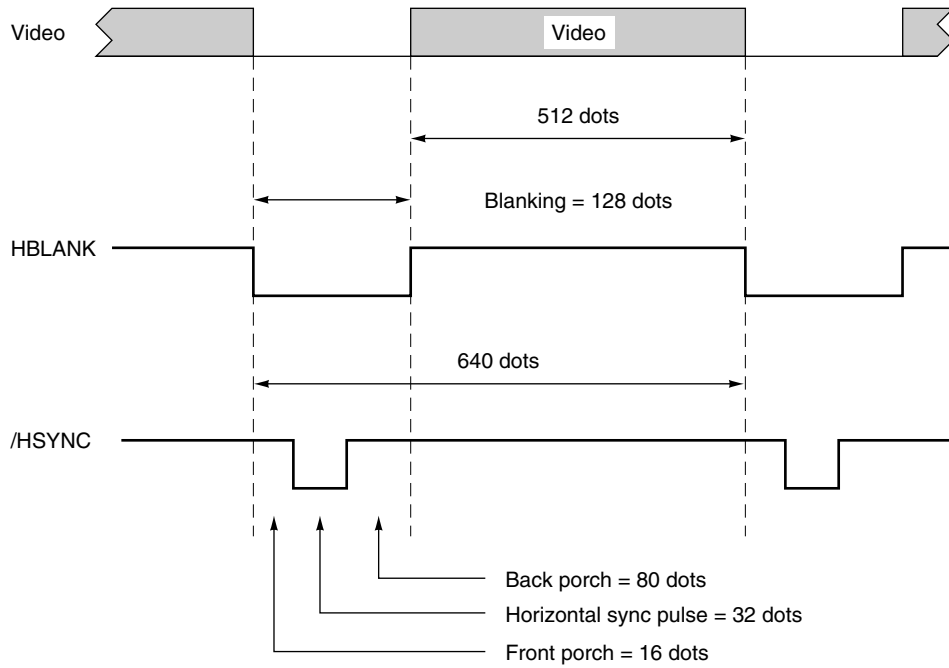

Vertical timing

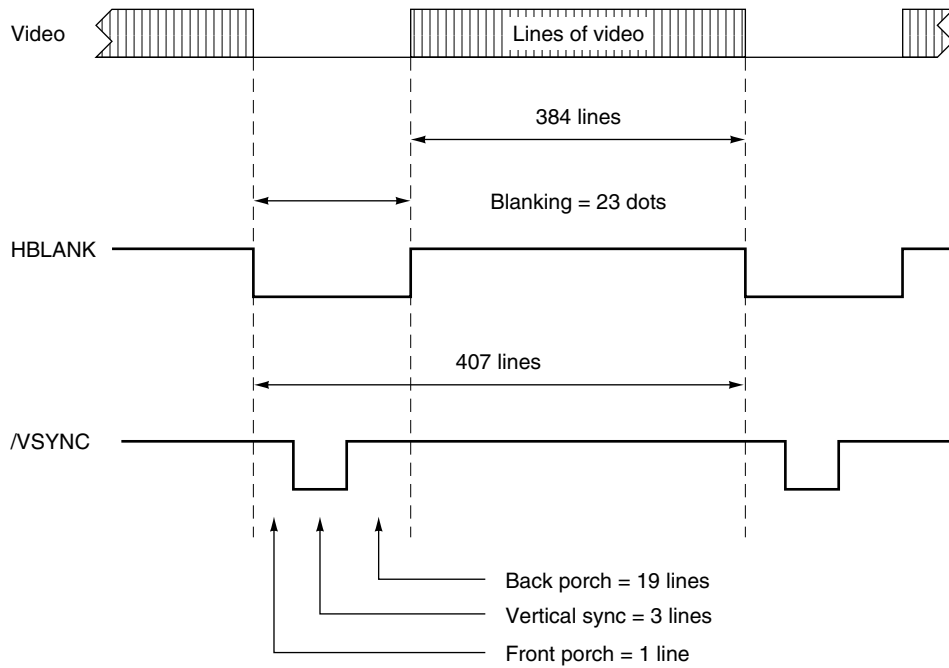

**Figure 2-5** Horizontal video timing for the Apple IIe card

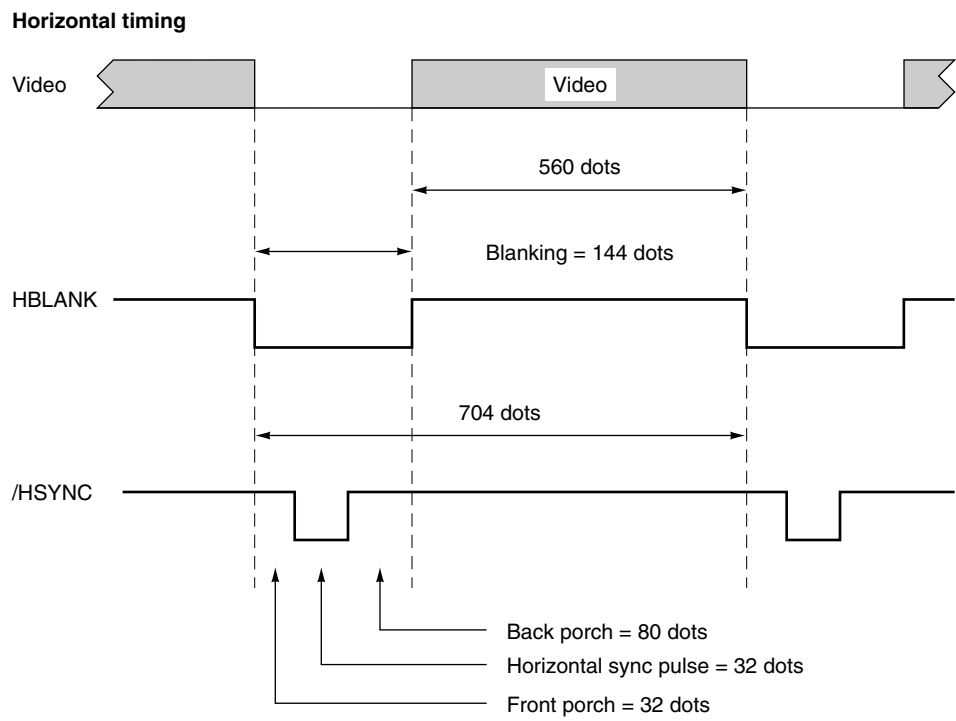





# Expansion Card

---

## Expansion Card

The expansion card for the Macintosh Color Classic computer is a PDS card that connects directly to the MC68030 microprocessor and provides additional functions. This chapter describes the expansion card and lists the signals on the expansion connector.

## The PDS Expansion Card

The PDS expansion card for the Macintosh Color Classic computer is approximately 3 inches by 5 inches and plugs into a 96-pin connector on the main logic board. An opening in the case accepts a 15-pin D-type connector for external I/O to and from the card.

Figure 3-2 shows the dimensions of the PDS card for the Macintosh Color Classic. It is the same size and shape as the PDS card for the Macintosh LC. For complete mechanical specifications of the PDS card, refer to Chapter 17 “Physical Design Guide for Macintosh PDS Expansion Cards” in *Designing Cards and Drivers for the Macintosh Family*, third edition.

### Address Space for the Expansion Card

The card’s address depends on the memory addressing mode. In 24-bit mode, the card appears in the address space \$E0 0000-\$EF FFFF; in 32-bit mode, the card appears in the address space \$8000 0000-\$FFFF FFFF. To match the conventions used by the Slot Manager, software should address the card as if it were in slot space \$E: either the 16 MB slot space \$FE00 0000-\$FEFF FFFF or the super slot space \$E000 0000-\$EFFF FFFF.

The expansion card must generate its own select signal from the address and function code signals on the connector. The card select signal must be disabled when FC0, FC1, and FC2 are all active; that condition corresponds to a function code of 111 (CPU Space). Figure 3-1 shows a typical logic circuit for generating the card select signal.

**Figure 3-1** Generating the card select signal

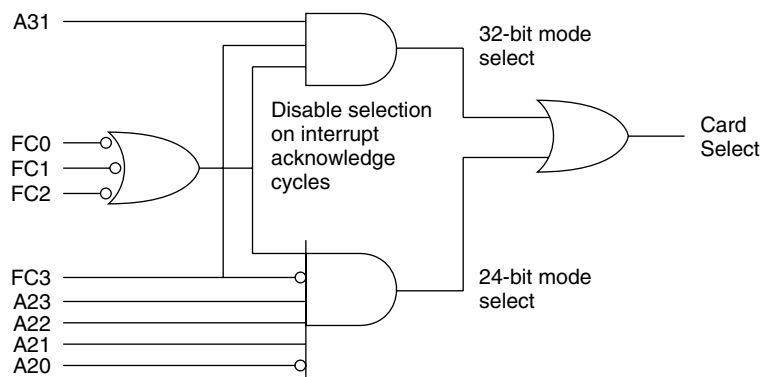



Expansion Card

**Figure 3-2** Design guide for the PDS card for the Macintosh Color Classic computer

- 1 Tooling holes; used for standoff.
- 2 Hole for standoff.
- 3 96-pin connector.
- 4 Shield plate required to maintain integrity of EMI/RFI seam.

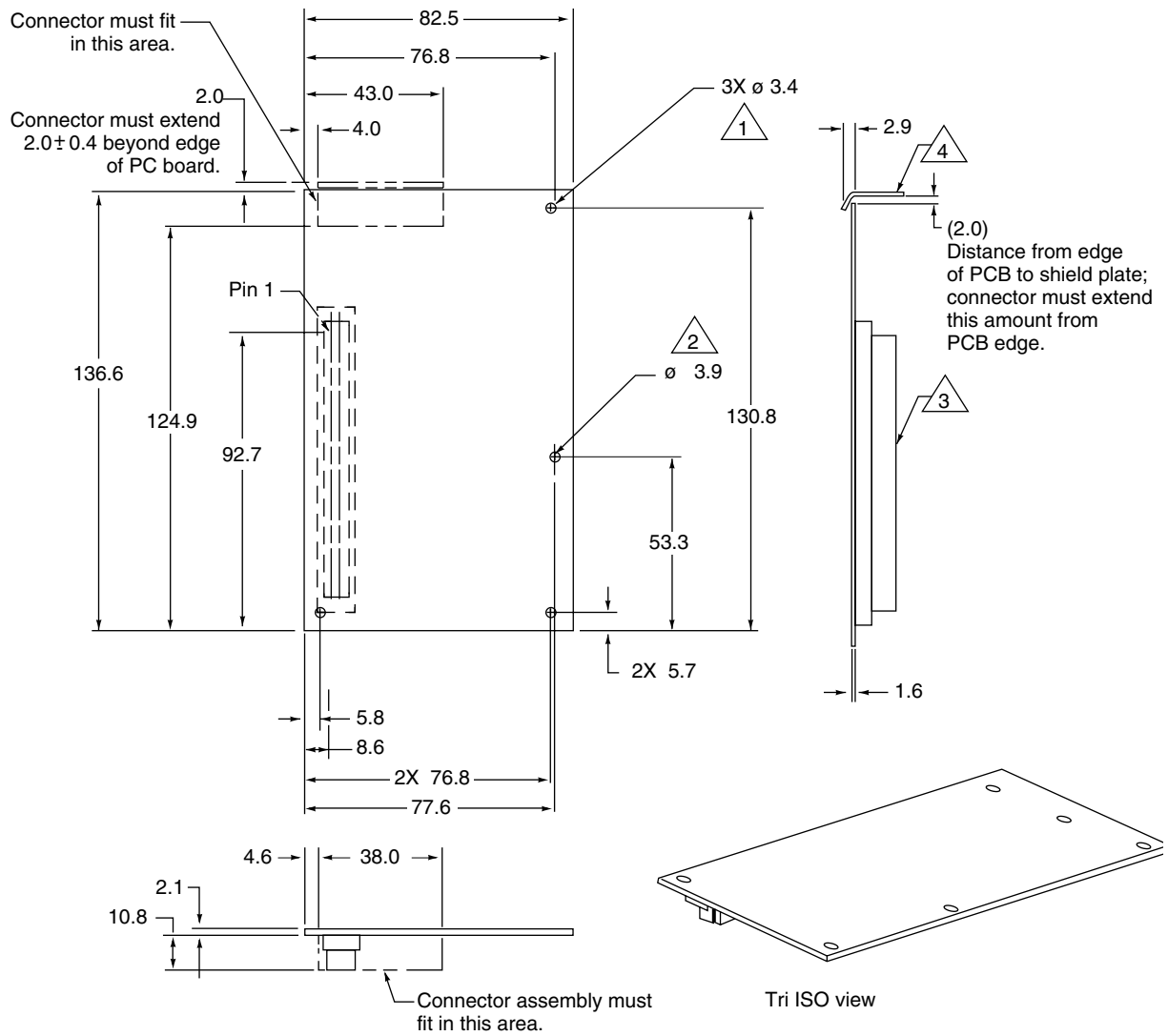

Dimensions are in millimeters.

## Power for the Expansion Card

---

The PDS card uses power supplied through the 96-pin connector. The maximum current available at each supply voltage is shown in Table 3-1. The card must not dissipate more than 5 W total; for example, if the card uses the maximum current at -5 V and +12 V, it must not use more than 500 mA from the +5 V supply.

▲ **WARNING**

Cards dissipating more than 5 watts may overheat and damage the computer's circuitry or cause it to become inoperable. ▲

**Table 3-1** Power available for the expansion card

| Voltage | Current |
|---------|---------|
| + 5     | 1.0 A   |
| - 5     | 20 mA   |
| + 12    | 200 mA  |

## The PDS Expansion Slot

---

The PDS expansion slot in the Macintosh Color Classic computer is a 96-pin Euro DIN connector. The pin assignments for the expansion connector are given in Table 3-2.

**Note**

The PDS connector in the Macintosh Color Classic computer is electrically the same as the PDS connector in the Macintosh LC II except for the absence of the FAN signal on pin A-31. If the card designer follows the guidelines in *Designing Cards and Drivers for the Macintosh Family*, third edition, PDS cards designed for the Macintosh LC II will work in the Macintosh Color Classic computer. ◆

Most of the signals are connected directly to the signal of the same name on the MC68030 microprocessor. Table 3-1 describes the functions of the processor-direct expansion connector signals. Table 3-3 gives the signal descriptions for those signals that are not connected to the MC68030.

## Expansion Card

**Table 3-2** Signals on the expansion connector

| Pin number | Row A    | Row B      | Row C   |
|------------|----------|------------|---------|
| 1          | SND      | Analog GND | /FPU    |
| 2          | /SLOTIRQ | R/W        | /DS     |
| 3          | /AS      | +5V        | /BERR   |
| 4          | /DSACK1  | +5V        | /DSACK0 |
| 5          | /HALT    | SIZ1       | SIZ0    |
| 6          | FC2      | GND        | FC1     |
| 7          | FC0      | C16M       | /RESET  |
| 8          | /RMC     | GND        | /BG     |
| 9          | D31      | D30        | D29     |
| 10         | D28      | D27        | D26     |
| 11         | D25      | D24        | D23     |
| 12         | D22      | D21        | D20     |
| 13         | D19      | D18        | D17     |
| 14         | D16      | D15        | D14     |
| 15         | D13      | D12        | D11     |
| 16         | D10      | D9         | D8      |
| 17         | /BGACK   | /BR        | A0      |
| 18         | A1       | A31        | A27     |
| 19         | A26      | A25        | A24     |
| 20         | A23      | A22        | A21     |
| 21         | A20      | /IPL2      | /IPL1   |
| 22         | /IPL0    | D3         | D4      |
| 23         | D2       | D5         | D6      |
| 24         | D1       | D0         | D7      |
| 25         | A4       | A2         | A3      |
| 26         | A6       | A12        | A5      |
| 27         | A11      | A13        | A7      |
| 28         | A9       | A8         | A10     |
| 29         | A16      | A15        | A14     |
| 30         | A18      | A17        | A19     |
| 31         | n.c.     | AllClock   | FC3     |
| 32         | +12V     | GND        | -5V     |

## Expansion Card

**IMPORTANT**

Under no circumstances should you use the Analog GND pin (Row B, pin 1) for a digital ground on an expansion card. Doing so will cause digital noise to be coupled into the audio system resulting in degraded sound quality. ▲

**Table 3-1** Processor-direct expansion connector signal descriptions

| Signal name         | Signal description  |
|---------------------|---|
| A0–A27, A30, A31    | Address lines.  |
| D0–D31              | Data lines.   |
| /AS                 | Address strobe. Three-state output signal indicating that valid operation is being attempted.   |
| /BERR               | Bus error. Bidirectional signal indicating that invalid bus operation is being attempted.   |
| /BG                 | Bus grant. Output signal indicating that external device can become bus master following completion of current processor bus cycle.   |
| /BR                 | Bus request. Input signal indicating that external device is requesting to become bus master.   |
| /BGACK              | Bus grant acknowledge. Input signal indicating that external device has become bus master.  |
| /DS                 | Data strobe. During read operation, /DS indicates that external device should place data on data bus; during write operation, /DS indicates that 68030 processor has placed valid data on the data bus. |
| /DSACK0–<br>/DSACK1 | Data transfer acknowledge signals that indicate completion of data transfer operation.  |
| FC0–FC2             | Function code used to identify address space of current bus cycle.  |
| /HALT               | Signal indicating that 68030 processor should suspend all bus activity.   |
| /IPL0–IPL2          | Interrupt priority-level lines.   |
| /RESET              | Bidirectional signal that initiates system reset.   |
| /RMC                | Three state output signal that identifies current bus cycle as part of indivisible read-modify-write operation.   |
| R/W                 | Read/write. Three state output signal that defines bus transfer as read or write operation.   |
| SIZ0–SIZ1           | Three state output signals that work in conjunction with processor's dynamic bus sizing capabilities to indicate number of bytes remaining to be transferred during current bus cycle.                  |

## Expansion Card

All the signals on the expansion connector are capable of driving at least one TTL load (1.6 mA sink, 400  $\mu$ A source). Most of the signals connect to other MOS devices on the main logic board; for those signals, the DC load on the bus signals is small. The high-order 16 data lines (D16–D31) have one LS load connected to them.

**Table 3-3** Expansion slot signals not connected to the MC68030

| Signal name | Signal description  |
|-------------|---|
| /SLOTIRQ    | Interrupt request from the card. When low, generates a Level 2 interrupt (if the Slot Interrupt Enable bit is set).   |
| SND         | Digital input to the speaker amplifier so that the card can drive the speaker independently of the main processor; requires 470 K $\Omega$ in series.                     |
| C16M        | Main processor clock (15.6672 MHz).   |
| /FPU        | Select signal for an MC68881 or MC68882 floating point unit.  |
| FC3         | Additional function code bit, used to indicate that the software is running in 32-bit address mode. (As in the Macintosh LC II, the software always runs in 32-bit mode.) |
| AIIClock    | Input for a 17.234 MHz clock, needed to generate video signals for the Apple II video mode.   |

The SND input allows the expansion card to produce sound output by the method used on the original Apple II computer, using ones and zeroes.

▲ **WARNING**

The SND pin must not be grounded; doing so will short circuit the +5V power supply. If you don't use the SND pin, leave it unconnected. ▲



# Software

---

## Software

The first part of this chapter describes the software in ROM in the Macintosh Color Classic computer. The second part describes the system software that supports the new features of the Macintosh Color Classic computer.

## ROM Software

---

The ROM in the Macintosh Color Classic computer is based on the ROM for the Macintosh LC II with changes needed to support machine-specific hardware.

### Unchanged Functions

---

Many ROM software components in the Macintosh Color Classic are functionally the same as their counterparts in the Macintosh LC II. Those components are

- Slot Manager
- Network booting routines
- Color QuickDraw
- Floating-point arithmetic routines
- SANE routines

The AppleTalk routines are no longer in the ROM; they are now in the system software, but they are similar to their counterparts in the ROM in the Macintosh LC II.

### MMU Initialization

---

The code has been modified to support the memory addressing used by the Macintosh Color Classic. There are new MMU tables to match the address mapping.

### Machine Identification

---

The ROM includes new tables and code for identifying the machine.

Applications can find out which computer they are running on by using the Gestalt Manager routines or by calling `SysEnviron`s. The Gestalt 'mach' value for the Macintosh Color Classic computer is 49 (hexadecimal \$31); the `SysEnviron`s machine type is 47 (hexadecimal \$2F).

### RAM Sizing and Addressing

---

For determining the size of RAM and for setting up the MMU to make the RAM addresses contiguous, the Macintosh Color Classic uses code modified from that used in the Macintosh LC II.



## Software

For address decoding, the Macintosh Color Classic computer uses the same code as the Macintosh LC II. To be able to run with virtual memory active, the Macintosh Color Classic uses the 32-bit Memory Manager and runs in 32 bit mode.

## One-Second Interrupt

---

As on the Macintosh LC II, the one-second interrupt on the Macintosh Color Classic computer is provided by the ADB microcontroller, which sends the one-second interrupt to the main processor as a pseudodevice transaction. In those cases where a one-second interrupt was missed, the ADB microcontroller sends the current value of the real-time clock so that the system software can update the value stored in the `Time` global variable.

## Pushbutton Interrupts

---

The ROM in the Macintosh Color Classic includes new routines for initializing the pushbutton interrupt bits in the interrupt enable and flag registers and for initializing other new registers that support the pushbuttons.

If the pushbutton interrupt is enabled by the Interrupt Enable Register, pushing any of the four pushbuttons on the front of the case causes the machine to set a bit in a new register, the Pushbutton register, which in turn causes a level-2 interrupt. The interrupt handler then disables the pushbutton interrupt until the button that caused the interrupt is released.

When a pushbutton is pressed, the Time Manager sets one or more tasks to debounce the pushbutton, increments or decrements the value associated with the pushbutton by a set amount, then continues to increment or decrement the pushbutton value as long as the pushbutton is held down.

## Screen Driver

---

Applications can read and set the brightness and contrast of the screen by making appropriate status and control calls to the Screen driver (`.BCScreen`). The system startup code uses the Screen driver to set the initial screen values.

The current values of brightness and contrast are stored as byte values in parameter RAM. If the startup software finds that the contrast value is below the minimum startup value, it sets it to the minimum startup value. If the brightness and contrast values are zero, the startup software sets them to default values near the middle of their ranges.

**IMPORTANT**

The Screen driver is machine specific and does not represent a solution that will support all Macintosh models. ▲

Software

## Screen Driver Calls

---

Screen driver calls use the `ParamBlockRec` method as described in the Device Manager chapter of *Inside Macintosh*. The parameter passing conventions are the standard ones: the calling program passes a pointer to the parameter block in register A0.

Because the Screen driver is opened at startup and is never closed, and because there is nothing to read or write, the following calls are not supported:

- KillIO
- CloseDriver
- FSRead
- FSWrite

## Open

---

```
PBOpen (paramBlock: ParmBlkPtr; async: BOOLEAN) : OSErr_Open
```

### Parameter block

```
→ ioCompletion    Nil.
← ioResult        noErr (zero).
→ ioNamePtr       Pointer to the name .BCScreen.
← ioRefNum        Driver's reference number.
→ ioPermsn        Must be fsCurPerm.
```

When the system software opens the Screen driver at startup time, the Device Manager creates a DCE and stores the handle in the proper unit table entry. Subsequent Open calls merely return `refNum` and result (`noErr`). Programs can use the Open call to obtain the `refNum` value for use in control and status calls.

High-level call:

```
OpenDriver (name: Str255; VAR refNum: INTEGER) : OSErr
```

## Control

---

```
PBControl (paramBlock: ParmBlkPtr; async: BOOLEAN) : OSErr_Control
```

### Parameter block

```
→ ioCompletion    Nil.
← ioResult        controlErr (-17) if csCode is unimplemented; otherwise
                  noErr (0).
→ ioRefNum        Driver's reference number.
→ csCode          Identifies the call; described below.
→ csParam         Depends on the call; described below
                  (csParam is an array of 11 shorts).
```

## Software

## csCode values:

| Name           | Value  | Description  |
|----------------|--------|--|
| CtrlScrnBright | \$4301 | Set screen brightness PWM value between 0 and 255 in csParam[0]. |
| CtrlSaveBright | \$4302 | Store current brightness to PRAM.                                |
| CtrlScrnCont   | \$4307 | Set screen contrast PWM value between 0 and 255 in csParam[0].   |
| CtrlSaveCont   | \$4308 | Store current contrast to PRAM.                                  |
| CtrlScreenOff  | \$4309 | Turn off power to internal monitor.                              |
| CtrlScreenOn   | \$4310 | Turn on power to internal monitor.                               |

## High-level call:

```
Control(refNum: INTEGER; csCode: INTEGER; csParamPtr: Ptr) : OSerr
```

---

**Status**

```
PBStatus (paramBlock: ParmBlkPtr; async: BOOLEAN) : OSerr_Status
```

**Parameter block**

|   |              |  |
|---|--------------|--|
| → | ioCompletion | Nil.   |
| ← | ioResult     | controlErr (-17) if csCode is unimplemented; otherwise noErr (0).        |
| → | ioRefNum     | Driver's reference number.   |
| → | csCode       | Identifies the call; described below.                                    |
| → | csParam      | Depends on the call; described below (csParam is an array of 11 shorts). |

## csCode values:

| Name           | Value  | Description  |
|----------------|--------|--|
| StatScrnBright | \$5301 | Return current screen brightness in csParam[0] (value = 0-255).  |
| StatBrtnMinMax | \$5303 | Return min and max brightness values<br>csParam[0] = max brightness,<br>csParam[1] = min brightness.                     |
| StatScrnCont   | \$5307 | Return current screen contrast in csParam[0] (value = 0-255).  |
| StatConMinMax  | \$5308 | Return min and max contrast values<br>csParam[0] = max contrast,<br>csParam[1] = min contrast.                           |
| StatScrnOnOff  | \$5309 | Return on/off state of internal monitor in csParam[0]<br>\$00FF = monitor power is on,<br>\$0000 = monitor power is off. |

## High-level call:

```
Status(refNum: INTEGER; csCode: INTEGER; csParamPtr: Ptr) : OSerr
```

Software

## Power Saver Software

---

The software that controls the brightness of the display also includes code that implements the power saver mode, which turns off the power to the display after a set interval of time. Applications can turn the monitor on and off and read its status by making the appropriate call to the Screen driver (`.BCScreen`); see the description of the screen calls in the earlier section “Screen Driver Calls.”

### Note

The screen can remain dark for several seconds after the screen is reactivated, so the system emits a series of beeps to help reassure the user that the computer is still operating. The Screen driver call that turns on the monitor causes a call to the Notification Manager to play `SysBeep` sounds. When the screen is reactivated, the keyboard and mouse are disabled until the screen reappears. ♦

## Video Software

---

Video support on the Macintosh Color Classic computer uses the same code as the Macintosh LC II. The only difference is that VRAM is always present.

# System Software

---

The Macintosh Color Classic computer requires System 7.1 or later system software. The disk labeled *InstallMeFirst* includes a system enabler file that contains the resources the system needs to start up and initialize the Macintosh Color Classic computer.

The *InstallMeFirst* disk also includes an installer application to install the control panels for the new features of the machine.

## System Enabler

---

Starting with the international release of System 7.1, each reference release of the Macintosh system software supports a new startup extension, the system enabler. The **system enabler** is a software resource that is able to perform the correct startup process for one or more Macintosh computers.

As soon as the system software on disk takes over the startup process, it searches for all system enablers that can start up the particular machine. Each system enabler contains a resource that specifies which computers it is able to start up and the time and date of its creation. If the system software finds more than one enabler for the particular computer, it passes control to the one with the most recent time and date.

## Software

In general, the system enabler included in each reference release of system software is able to start up all previous computers. The system enabler that accompanies a later computer will be able to start up that computer, possibly using resources from the previous reference release.

## New Control Panels

The Macintosh Color Classic system software includes new control panels for the sound level and the screen brightness and contrast.

### Sound Control Panel

The Sound control panel on the Macintosh Color Classic computer is able to update its slider to reflect changes in the sound level caused by the user pressing one of the sound pushbuttons on the front of the case. Figure 4-1 shows the Sound control panel.

**Figure 4-1** Sound control panel

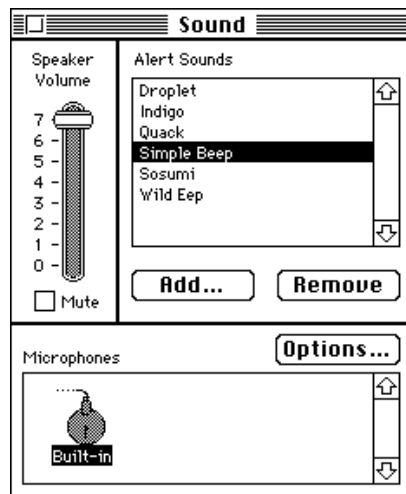

The control panel also has a Mute checkbox to turn off the sound. When the user adjusts the sound level, either with the control panel or the pushbuttons, the Mute checkbox is automatically turned off.

The Sound control panel also allows the user to select the source of sound input, which can be either the built-in microphone or a device plugged into the sound input jack. When the user clicks on the Options button, a dialog box appears, as shown in Figure 4-2. The user can then select either the internal microphone, an external microphone, or the line-level inputs.

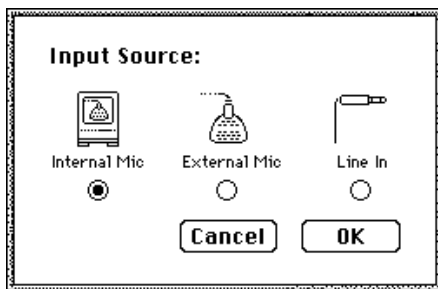
**Figure 4-2** Sound options

Either the external microphone or line-level inputs can be plugged into the sound input jack. When the user selects the corresponding input device in the Sound control panel, the computer sets the gain appropriately.

### Screen Control Panel

The Screen control panel has sliders for adjusting brightness and contrast. The user can adjust either slider by dragging with the mouse and can adjust the contrast using the arrow keys or the number keys. Figure 4-3 shows the Screen control panel.

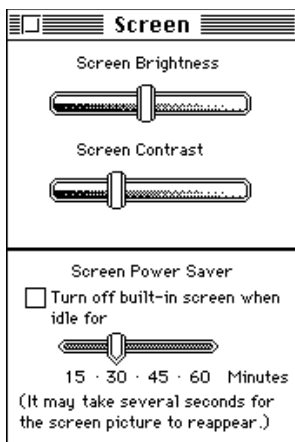
**Figure 4-3** Screen control panel

#### Note

The Screen control panel uses minimum and maximum values supplied by the Screen Driver so as not to set the screen so dark that the user cannot see the Control Panel to make further adjustments. For information about the Screen Driver, see the section "Screen Driver" beginning on page 37. ♦

# Index

---

## Numerals

---

24-bit addressing 19  
32-bit addressing 19, 37  
68HC05 microcontroller 18

## A

---

abbreviations ix  
access to the logic board 3  
accuracy of information vii  
ADB (Apple Desktop Bus) ports 9  
    connector 9  
ADB controller 18  
address map 20  
address modes 19  
Apple IIe card 7, 23  
Apple SuperDrive 7

## B

---

block diagram 17

## C

---

clock speed 16  
CLUT 22  
color look-up table (CLUT) 22  
Combo IC 16  
connectors  
    ADB 9  
    floppy disk 7  
    SCSI 8  
    serial I/O 9  
    sound input 12, 42  
    sound out 18  
control panels  
    screen 42  
    sound 41  
custom ICs  
    Combo 16  
    DFAC2 18  
    Spice 16, 18

## D

---

DFAC2 custom IC 18  
disclaimer vii  
display  
    dimming by power saver 10

## E

---

expansion card. *See* PDS card

## F

---

features summary 2  
floppy disk  
    connector 7  
floppy-disk controller 16  
FPU (floating point unit) 16

## G, H

---

Gestalt Manager 36  
GPi (general-purpose input) signal 9, 18

## I, J

---

I/O address map 21

## K, L

---

keyboard  
    power key 10, 12  
    Reset and NMI functions 12

**M, N**

---

machine identification 36  
 master power switch 10  
 MC68030 microprocessor  
   clock speed 16  
   signals on PDS 30  
 microphone  
   built-in 11  
   connector 12, 42  
   power for 12

**O**

---

one-second interrupt 37

**P, Q**

---

parameter RAM 18  
 PDS (processor direct slot) 7, 28  
 PDS card 28  
   addresses 28  
   card-select signal 28  
   compatibility with Macintosh LC II 30  
   dimensions 28  
   maximum power 30  
   signal loading 33  
 PDS connector 30  
   signals 30  
 power  
   safe shutdown 10  
 power for PDS card 30  
 power key 10, 12  
 power saver 10, 11, 40  
 power switch 10  
   location of 3  
 Pushbutton register 37  
 pushbuttons  
   location of 3  
   screen control 5  
   sound level 12

**R**

---

RAM  
   address space 22  
   configurations 6  
   expansion 5  
   maximum size 6  
   upper 2 MB always used 22  
 RAM SIMMs  
   access time 5  
 removing the logic board 3

**S**

---

Screen control panel 42  
 screen control pushbuttons 5  
 Screen driver 37  
   calls not supported 38  
   control call 38  
   Open call 38  
   Status call 39  
 SCSI connectors 8  
 SCSI controller 16  
 serial I/O controller 16  
 serial I/O ports 9  
 sound  
   filters 19  
   microphone 11  
   modes of operation 18  
   no channel B 22  
   output connector 18  
   playthrough feature 18  
   pushbuttons 12  
   sample rates 19  
 sound buffer 22  
 sound circuits 18  
 Sound control panel 41  
 sound input jack 12, 42  
 Spice custom IC 16, 18  
 standard abbreviations ix  
 summary of features 2  
 SysEnviron function 36  
 System 7.1 40  
 system enabler 40  
 system software 40



T, U

---

Time Manager 37

V, W, X, Y, Z

---

VIA registers 16

video display

bits per pixel 5

dimensions 4

for Apple IIe card 5, 23

intensity of 5

screen size 4

timing 23

video RAM. *See* VRAM

virtual memory 37

VRAM 22

expansion 5

SIMM 22

VRAM data bus 22